

# LED Canopy Light-B

100W / 120W / 150W / 200W / 240W

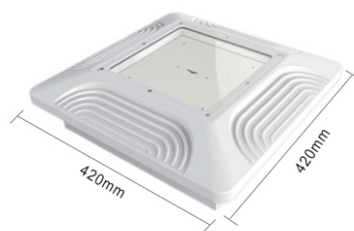

100W / 120W / 150W

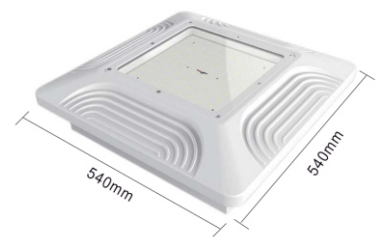

200W / 240W



## Application

Suitable for food processing and packing areas, service station canopies, car parks, retail areas, shopping malls and manufacturing facilities

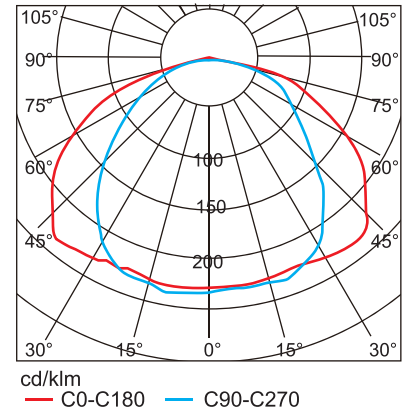

## Technical Specification

Item	UL-CL100W-B	UL-CL120W-B	UL-CL150W-B
Power	100W	120W	150W
Lumen (±10%)	12500lm	15000lm	18750lm
Dimension	420*420*67mm	420*420*67mm	420*420*67mm
Voltage	AC85V-265V~50/60Hz		
LED Type	Philips 3030		
LED Integrated Driver	Meanwell/HLG series		
Color Temperature(CCT)	2700K-6500K		
Beam Angel	120°		
Color Tempering Index(CRI)	Ra > 80		
Power Supply Efficiency	> 90%		
LED Luminous Efficiency	125lm/W		
Power Factor(PF)	> 0.9		
Total Harmonic Distortion(THD)	≤ 15%		
IP Rank	IP65		
Certificate	C-TICK, SAA, CE, CB		
Material	AL		
G.W	6KG		

Item	UL-CL200W-B	UL-CL240W-B
Power	200W	240W
Lumen (±10%)	25000lm	30000lm
Dimension	540*540*67mm	
Voltage	AC85V-265V~50/60Hz	
LED Type	Philips 3030	
LED Integrated Driver	Meanwell/HLG series	
Color Temperature(CCT)	2700K-6500K	
Beam Angel	120°	
Color Tempering Index(CRI)	Ra > 80	
Power Supply Efficiency	> 90%	
LED Luminous Efficiency	125lm/W	
Power Factor(PF)	> 0.90	
Total Harmonic Distortion(THD)	≤15%	
IP Rank	IP65	
Certificate	C-TICK,SAA,CE,CB	
Material	AL	
G.W	6.7KG	

## Installation instruction

### ① Ceiling Mounted Installation

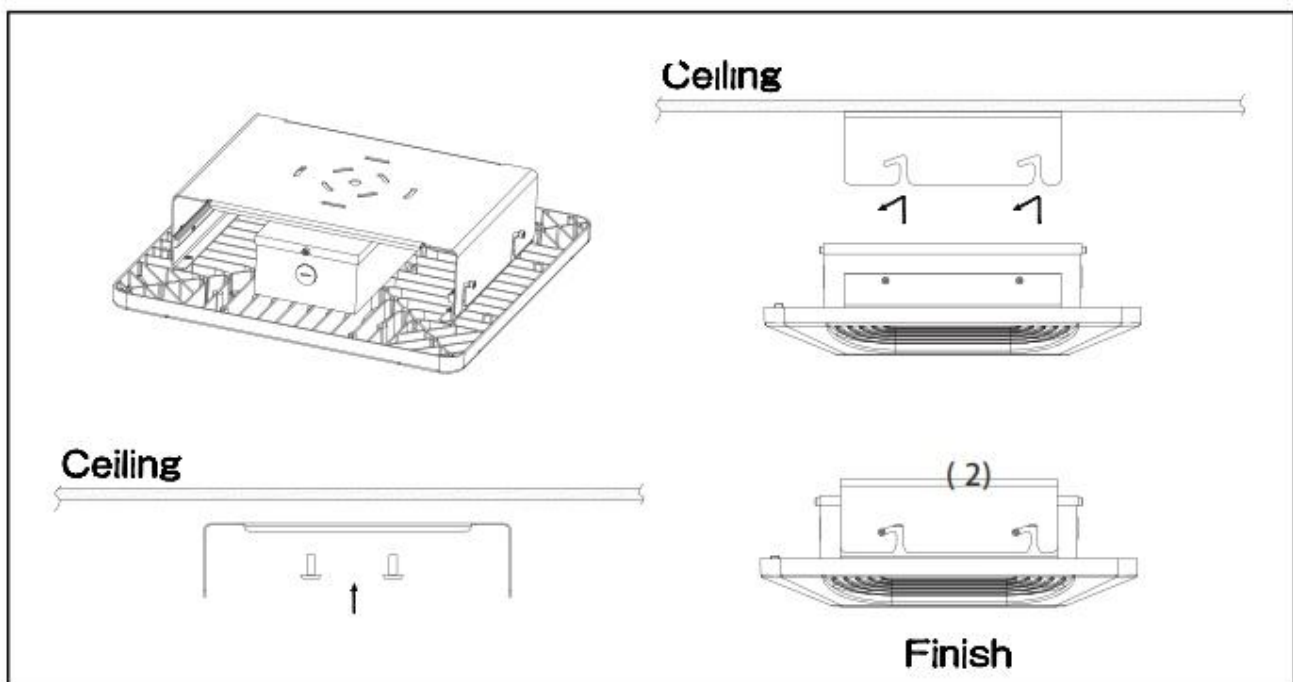

② Recessed Installation

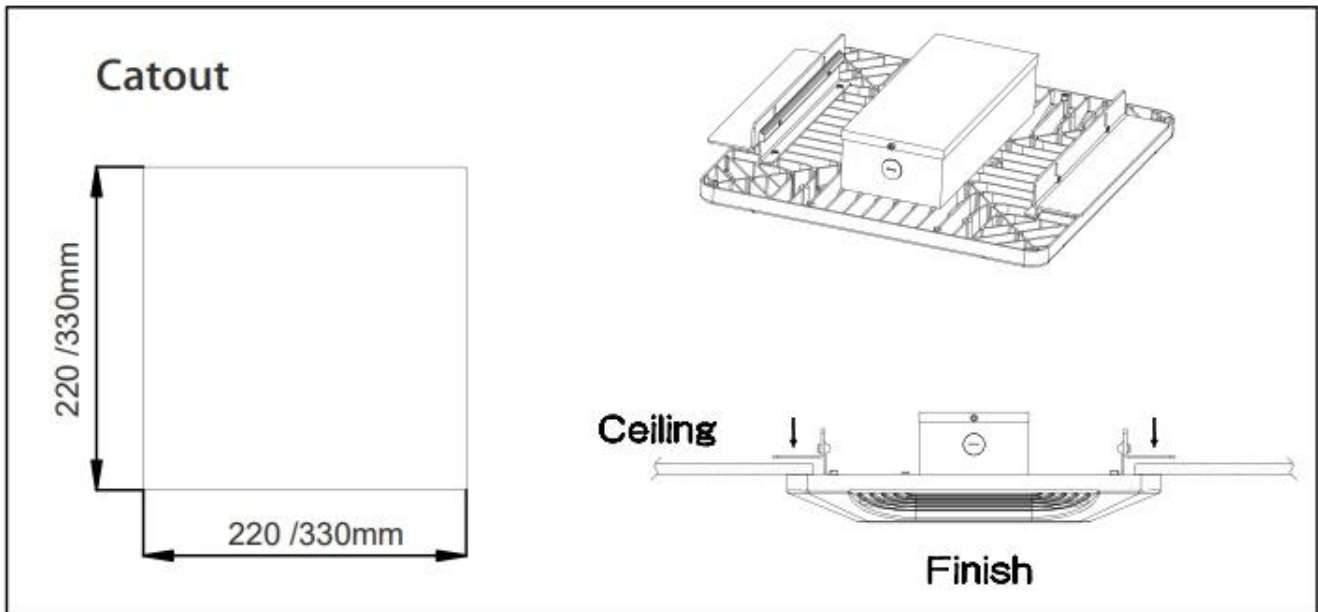

③ Ceiling Mounted Installation

