

LED Canopy Light

100W / 150W / 200W

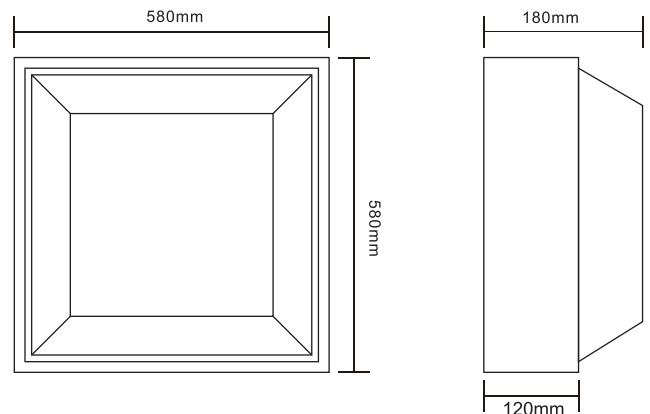
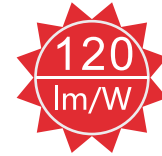

Application

Suitable for food processing and packing areas, service station canopies, car parks, retail areas, shopping malls and manufacturing facilities

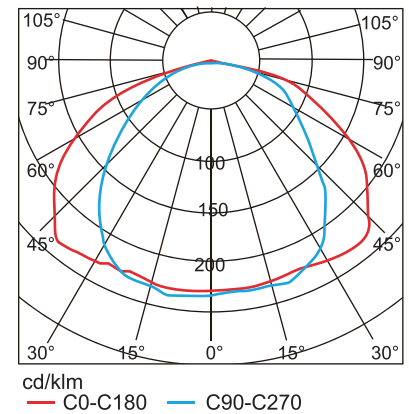

Technical Specification

Item	UL-CL100W	UL-CL150W	UL-CL200W
Power	100W	150W	200W
Lumen (±10%)	12000lm	18000lm	24000lm
Dimension	580*580*180mm	580*580*180mm	580*580*180mm
Voltage	AC100V-240V~50/60Hz		
LED Type	Lumileds 3030 2D		
LED Integrated Driver	MEANWELL/SOSEN		
Color Temperature(CCT)	2700K-6500K		
Beam Angel	120°		
Color Tempering Index(CRI)	Ra > 80		
Power Supply Efficiency	> 95%		
LED Luminous Efficiency	120lm/W		
Power Factor(PF)	> 0.95		
Total Harmonic Distortion(THD)	≤ 15%		
IP Rank	Ip65		
Certificate	C-TICK,SAA,CE		
Material	PC+AL		