

LED UFO High Bay light-AS

60W

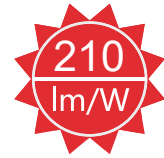

Features:

- Cold forging process, high stability
- High lumen efficiency and color rendering
- No flickering, non dazzling, high brightness
- Long life span, 5year warranty
- OEM available



motion+daylight sensor
detection area:6-12m
dimming function:0%/20%/50%
dimming time:30s/60s/5min/15min/30min
with remote control

Application

This product is suitable for factories, workshops, warehouse, toll stations, gas stations, stadiums, big supermarket, exhibition hall, commercial building, stadium hall, parking building etc.



Dimension (Unit: mm)

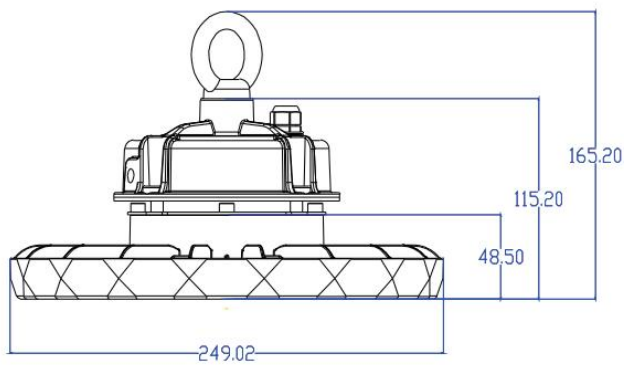

A: Technical Parameter

Item	UL-H60W-AS
Dimension	φ249X165mm
Voltage	AC85V- 265V~50/60HZ
Power	60W
Lumen (±10%)	126000lm
LED Type	Shenzhen Refond SMD2835
Color Temperature (CCT)	2700K-6500K
Beam Angel	Adjustable to 60°,90° and 120° (default is 120°)
Color Rendering Index (CRI)	Ra>70
Power Supply Efficiency	>95%
Luminous Efficiency	210lm/W
Power Factor (PF)	>0.95
IP Rank	IP 65
Certificate	SAA/CEET
Material	AL+tempered glass
N.W	2.63kg

B: Environmental

Temperature Range Operating	-40°C to 50°C
Humidity Range Operating	10% to 80%
Temperature Range Storage	-25°Cto 65°C
Humidity Range Storage	10% to 80%

Plane Isolux Curve & Illumination Cone Curve

60W

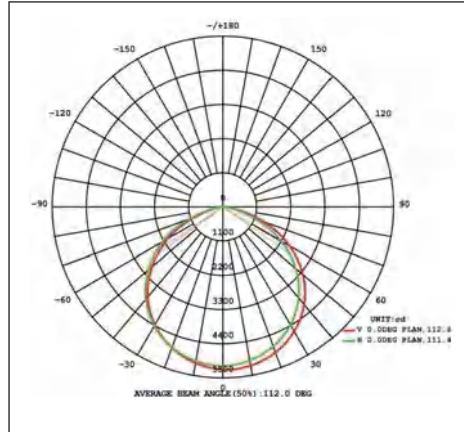

Height	Eavg, Emax	Angle: 111.41deg	Diameter
1m	1566, 5227lx		293.26cm
2m	391.6, 1307lx		586.53cm
3m	174.0, 580.7lx		879.79cm
4m	97.90, 326.7lx		1173.06cm
5m	62.66, 209.1lx		1466.32cm
6m	43.51, 145.2lx		1759.59cm
7m	31.97, 106.7lx		2052.85cm
8m	24.48, 81.66lx		2346.12cm
9m	19.34, 64.53lx		2639.38cm
10m	15.66, 52.27lx		2932.64cm

Installation

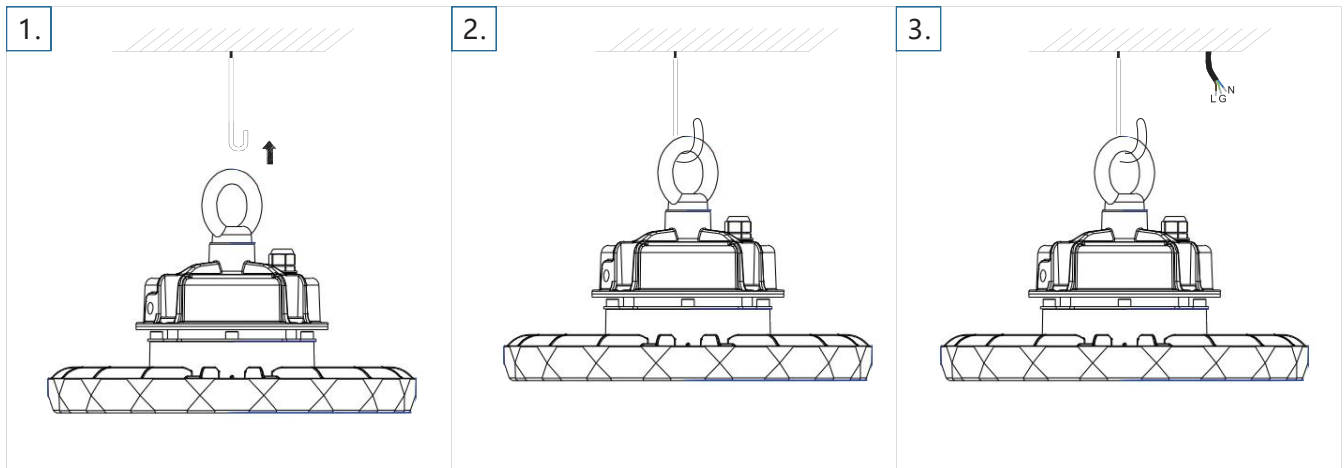

Drilling a hole in the ceiling, install a hook.

Hanging the fixture.

Connect the cables. Brown-L, Blue-N, Yellow green-Ground take care of the waterproof processing.

Packing

MODEL	UL-H60W-AS
CTN SIZE	760X220X310mm
GW	8.4KG
QTY/CTN	4PCS

Compliance and Standards

1. Insulation Resistance

The IR shall be at least 50MΩ when apply 500Vdc between primary and secondary

2. Dielectric Strength (Hi-pot)

Input To Output 3750Vac 60Hz 1minute ≤3MA

When AC voltage of 3.75 kV is applied, and the voltage applied to the insulation under test is gradually raised from zero to the prescribed voltage in 1s, and held at that value for 60s between the inputs and output. Between the input and housing, the current sensitivity shall be less than 5mA. After this test, the adapter shall exhibit no electrical and mechanical abnormalities.

3. Leakage Current

The leakage current shall be less than 0.25mA for class II when power supply is operated maximum input voltage and maximum load.

4. Safety Standard

34A-1501NP IEC:60598-1:2008 IEC61347-1/A1:2010 IEC61347-2-13:2006 IEC62031:2008
 IEC62471:2006 IEC62471-2:2009:Passed
 EN60598-1/A11:2009 EN61347-2-13:2006 EN61347-1/A1:2011 EN62031:2008 EN62471:2008
 EN61195:1999 EN62493:2010:Passed

5. EMI/EMS Standard

EN55015:Passed
 EN61000-3-2:Passed
 EN61000-4-2:Passed

Remote For Dimming Sensors

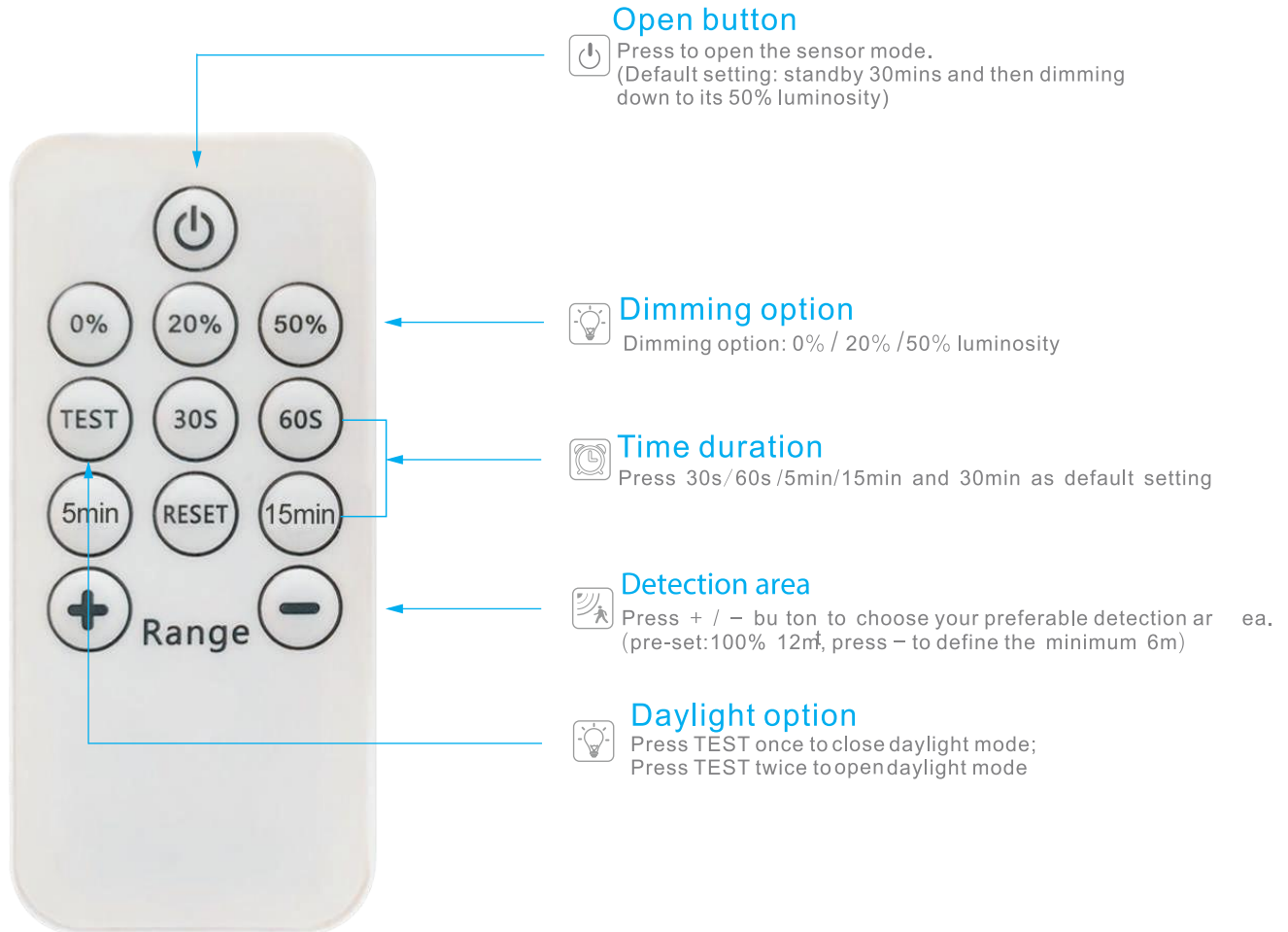

Attention

1. Please press  first if you want to change any setting.
2. When press any button, the light will flicker, it means the setting was recorded by the sensor.