

# LED UFO High Bay Light-HS

80W/100W/120W/150W

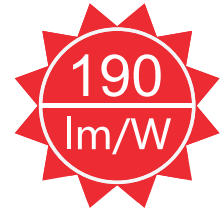

## Features:

- Cold forging process, high stability
- High lumen efficiency and color rendering
- No flickering, non dazzling, high brightness
- Long life span, 5 year warranty
- OEM available



### Sensor Optional

motion+daylight sensor  
detection area:6-12m  
dimming function:20%/50%  
dimming time:30s/60s/90s/120s/30min  
with remote control

## Application

This product is suitable for factories, workshops, warehouse, toll stations, gas stations, stadiums, big supermarket, exhibition hall, commercial building, stadium hall, parking building etc.



## Dimension (Unit: mm)

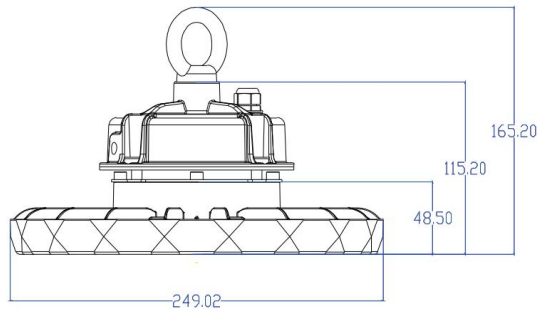

**80W/100W/120W**

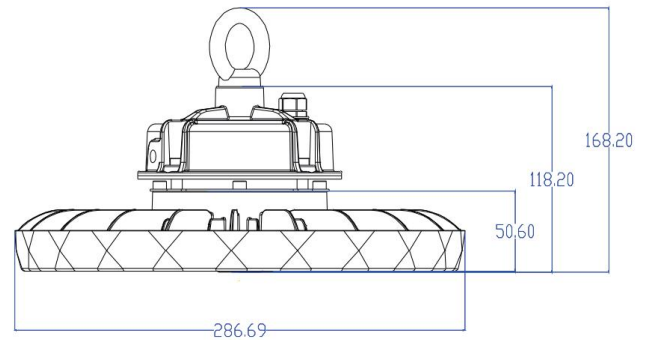

**150W**

## A: Technical Parameter

Item	UL-H80W-HS	UL-H100W-HS	UL-H120W-HS	UL-H150W-HS
Dimension	249X165mm	249X165mm	249X165mm	286X168mm
Voltage	AC85V- 265V~50/60HZ			
Power	80W	100W	120W	150W
Lumen (±10%)	15200lm	19000lm	22800lm	28500lm
LED Type	Shenzhen Refond SMD2835			
Color Temperature (CCT)	2700K-6500K			
Beam Angel	60° / 90° / 120°			
Color Rendering Index(CRI)	Ra > 70			
Power Supply Efficiency	>95%			
Luminous Efficiency	190lm/W			
Power Factor (PF)	>0.95			
IP Rank	IP 65			
Certificate	C-TICK, SAA, CE, CB			
Material	AL+tempered glass			
N.W	2.63kg	2.63kg	2.63kg	3.5kg

## B: Environmental

Temperature Range Operating	-40°C to 50°C
Humidity Range Operating	10% to 80%
Temperature Range Storage	-25°C to 65°C
Humidity Range Storage	10% to 80%

## Installation

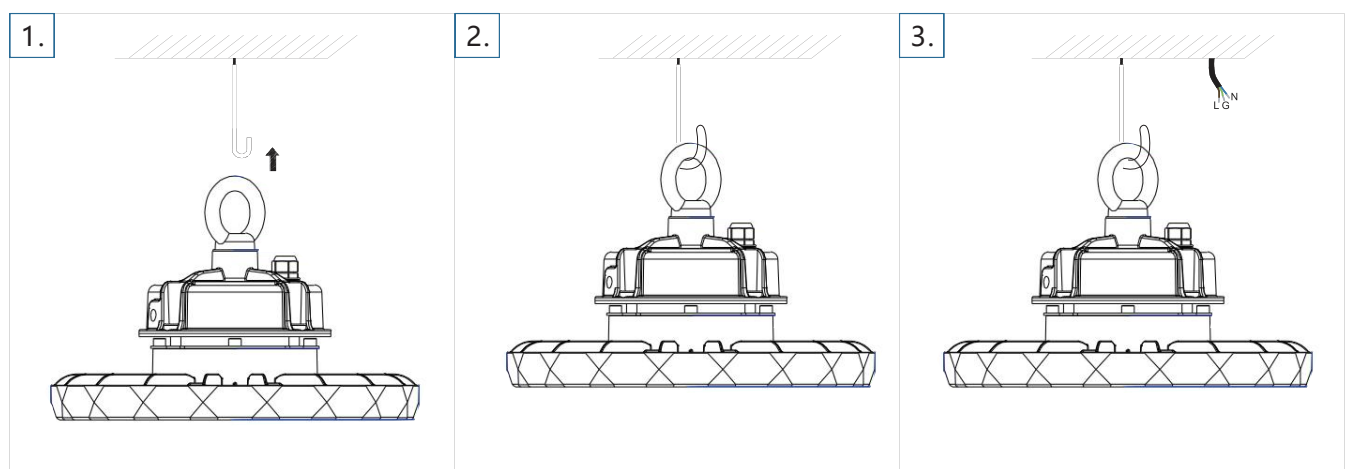

1. Drilling a hole in the ceiling, install a hook.

2. Hanging the fixture.

3. Connect the cables. Brown-L, Blue-N, Yellow green-Ground take care of the waterproof processing.

## Plane Isolux Curve & Illumination Cone Curve

80W

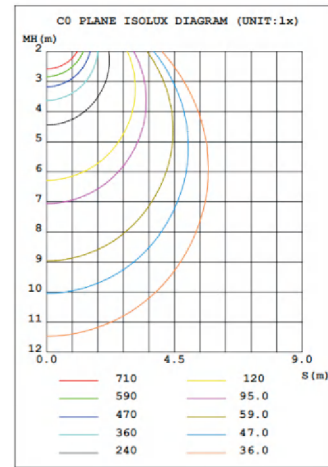
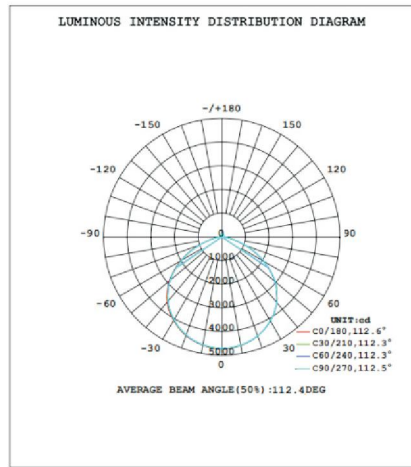

100W

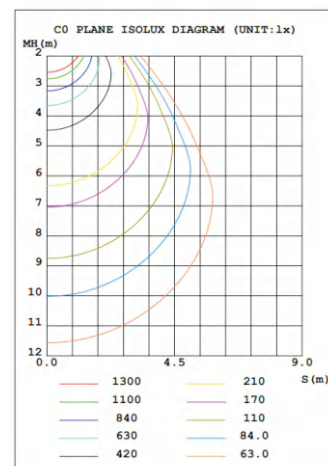
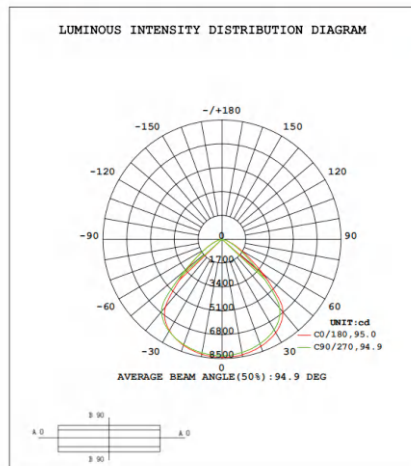

150W

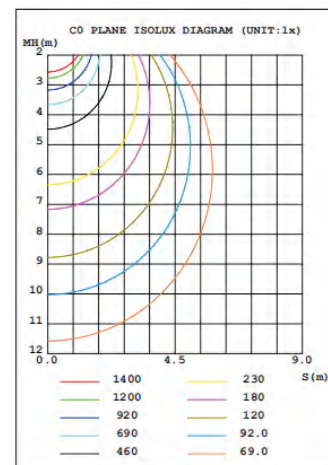
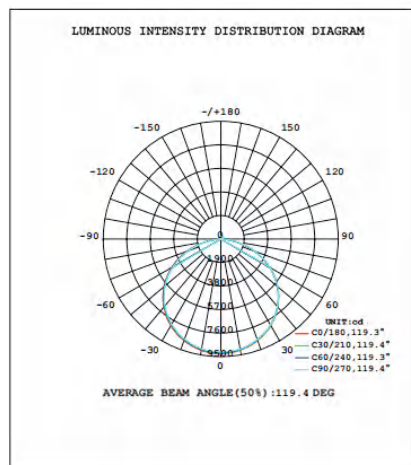

## Packing

MODEL	UL-80/100/120W-HS	UL-150W-HS
CTN SIZE	760X220X310mm	835X355X230mm
GW	8.4KG	10.42KG
QTY/CTN	4PCS	4PCS

## Compliance and Standards

### 1. Insulation Resistance

The IR shall be at least 50MΩ when apply 500Vdc between primary and secondary

### 2. Dielectric Strength (Hi-pot)

Input To Output 3750Vac 60Hz 1minute ≤3MA

When AC voltage of 3.75 kV is applied, and the voltage applied to the insulation under test is gradually raised from zero to the prescribed voltage in 1s, and held at that value for 60s between the inputs and output. Between the input and housing, the current sensitivity shall be less than 5mA. After this test, the adapter shall exhibit no electrical and mechanical abnormalities.

### 3. Leakage Current

The leakage current shall be less than 0.25mA for class II when power supply is operated maximum input voltage and maximum load.

### 4. Safety Standard

34A-1501NP IEC:60598-1:2008 IEC61347-1/A1:2010 IEC61347-2-13:2006 IEC62031:2008  
 IEC62471:2006 IEC62471-2:2009:Passed  
 EN60598-1/A11:2009 EN61347-2-13:2006 EN61347-1/A1:2011 EN62031:2008 EN62471:2008  
 EN61195:1999 EN62493:2010:Passed

### 5. EMI/EMS Standard

EN55015:Passed  
 EN61000-3-2:Passed  
 EN61000-4-2:Passed