

LED High Bay Light

100W / 150W / 200W



Features

- Cold forging process with high stability.
- High luminous flux efficiency and good color rendering.
- No flickering, no dazzling and high brightness.
- Long life span, 5 years warranty.
- OEM available.
- Remoted control Available.



Specifications

Model No	UL-H100W-FS-2	UL-H150W-FS-2	UL-H200W-FS-2
Power	100W	150W	200W
Dimension	249*165mm	286*168mm	328*174mm
Voltage	AC220-240V		
Material	AL+Tempered Glass		
Light Efficiency	155LM/W		
Lumen (±10%)	15500LM	23250LM	31000LM
Color Temperature (CCT)	5500K		
Beam Angel	120°		
Color Rendering Index (CRI)	Ra>70		
LED Type	SMD2835		
Power Factor (PF)	>0.95		
IP Rank	IP65		

Dimension(Unit:mm)

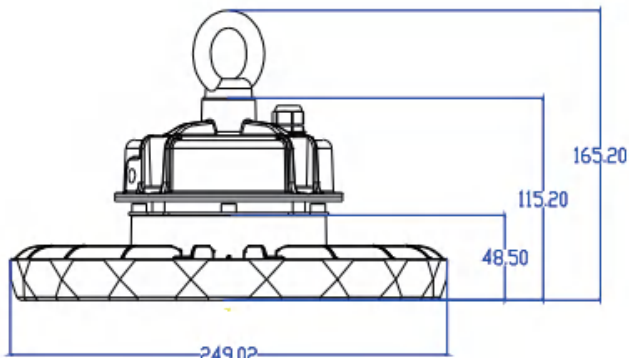

100W

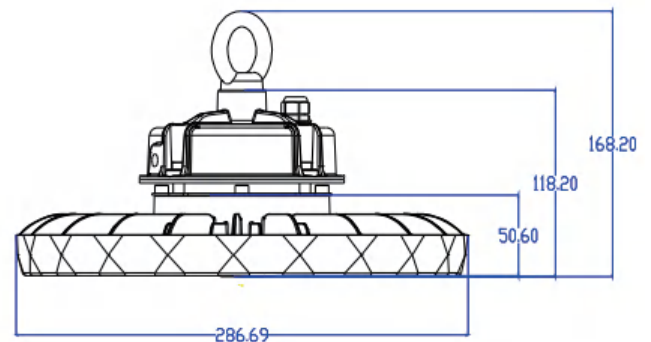

150W

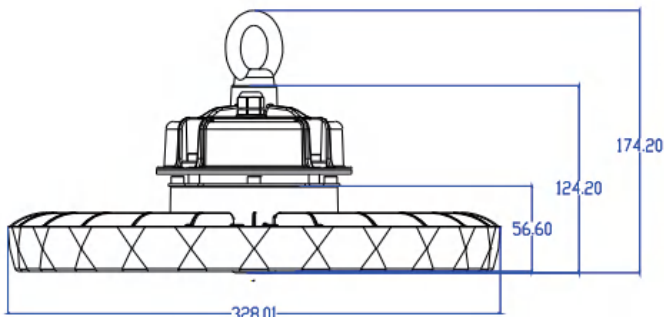

200W

Application

This product is suitable for factories, workshops, warehouse, toll stations, gas stations, stadiums, supermarket, exhibition, commercial building, stadium hall, parking building etc.



Warning

Please read these instructions carefully before commencing any work.

- This unit must be fitted by a competent and qualified electrician.
- To avoid damage, falling, electric shock, or fire, please do not modify the lamp and replace accessories without confirming with the supplier.
- Maintenance/installation and replacement of the lamp, please confirm to cut off the power supply, and the lamp has set up a cooling. Please make sure the lamp has been properly installed before processing power.
- Ensure the lamp is in an accurate and reliable connection.
- Ensure that the product around the vent, and the lamp cannot violate any fire prevention regulations when used.

Remote For Dimming Sensors

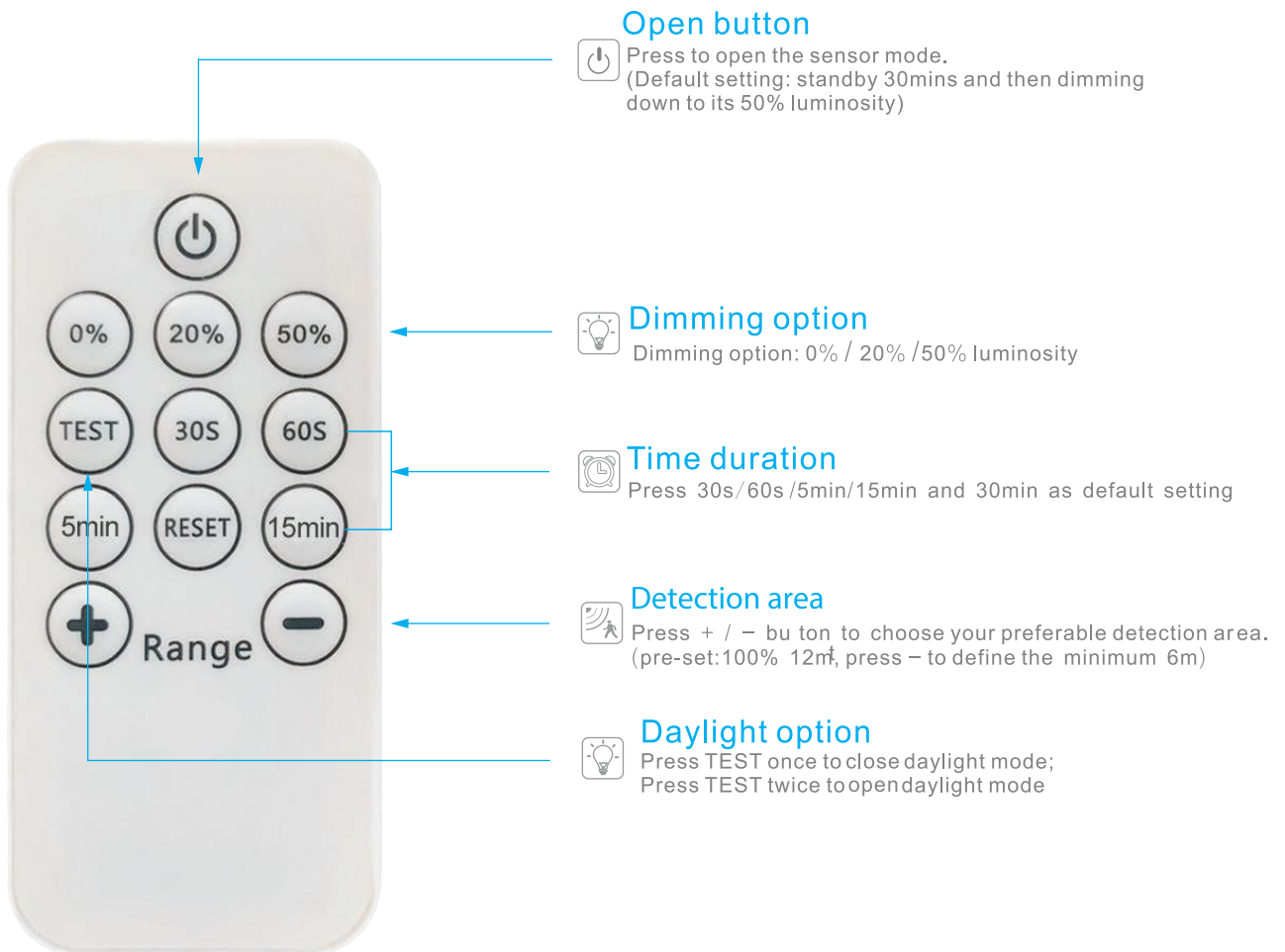

Attention

- 1.Please press first if you want to change any setting.
- 2.When press any button,the light will flicker,it means the setting was recorded by the sensor.