

LED High Bay Light

150W / 200W



Features

- Cold forging process with high stability.
- High luminous flux efficiency and good color rendering.
- No flickering, no dazzling and high brightness.
- Long life span, 5 years warranty.
- OEM available.
- Remoted control Available.



Specifications

Model No	UL-H150W-FS-3	UL-H200W-FS-3
Power	150W	200W
Dimension	286*168mm	328*174mm
Voltage	AC220-240V	
Material	AL+Tempered Glass	
Light Efficiency	140LM/W	
Lumen (±10%)	21000LM	28000LM
Color Temperature (CCT)	5500K	
Beam Angel	120°	
Color Rendering Index (CRI)	Ra>70	
LED Type	SMD2835	
Power Factor (PF)	>0.95	
IP Rank	IP65	
SENSOR	N/A	

Dimension(Unit:mm)

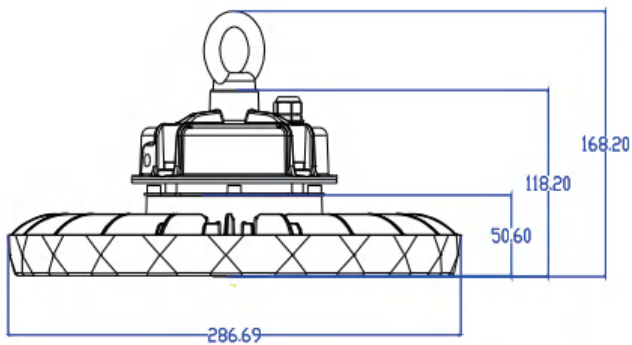

150W

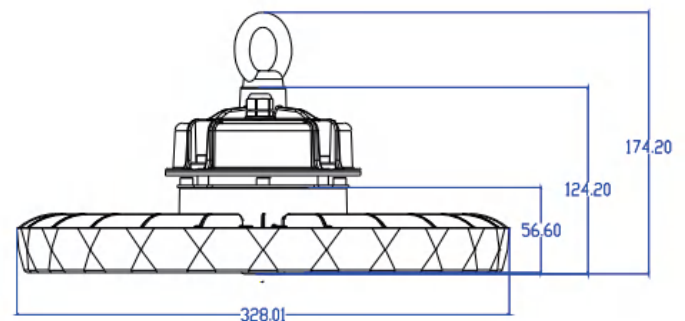

200W

Application

This product is suitable for factories, workshops, warehouse, toll stations, gas stations, stadiums, supermarket, exhibition, commercial building, stadium hall, parking building etc.



Warning

Please read these instructions carefully before commencing any work.

- This unit must be fitted by a competent and qualified electrician.
- To avoid damage, falling, electric shock, or fire, please do not modify the lamp and replace accessories without confirming with the supplier.
- Maintenance/installation and replacement of the lamp, please confirm to cut off the power supply, and the lamp has set up a cooling. Please make sure the lamp has been properly installed before processing power.
- Ensure the lamp is in an accurate and reliable connection.
- Ensure that the product around the vent, and the lamp cannot violate any fire prevention regulations when used.