

LED High Bay Light

60W



210
lm/W



Features

- Cold forging process with high stability.
- High luminous flux efficiency and good color rendering.
- No flickering, no dazzling and high brightness.
- Long life span, 5 years warranty.
- OEM available.
- Remoted control Available.



Specifications

Model No	ECO-H60W-AS-2
Power	60W
Dimension	249*165mm
Voltage	AC220-240V
Material	AL+Tempered Glass
Light Efficiency	210LM/W
Lumen (±10%)	12600LM
Color Temperature (CCT)	5500K
Beam Angel	120°
Color Rendering Index (CRI)	Ra>70
LED Type	SMD2835
Power Factor (PF)	>0.95
IP Rank	IP65

Dimension(Unit:mm)

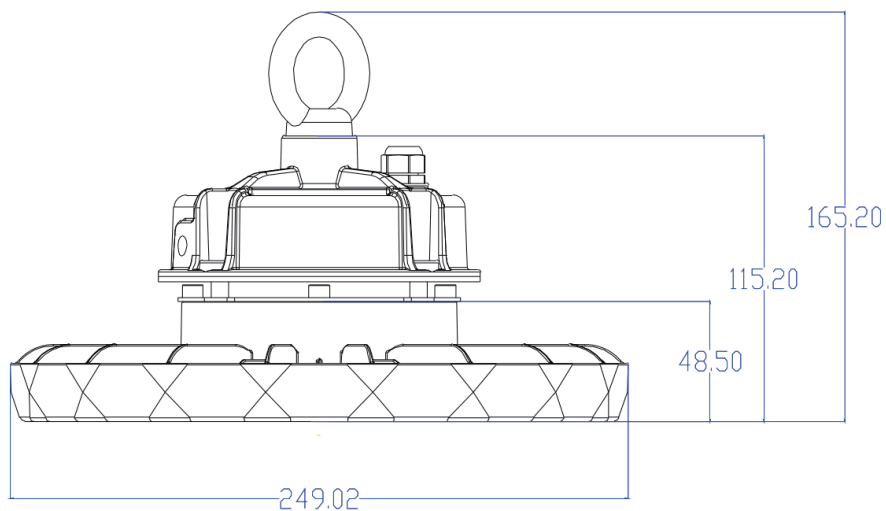

Application

This product is suitable for factories, workshops, warehouse, toll stations, gas stations, stadiums, supermarket, exhibition, commercial building, stadium hall, parking building etc.



Warning







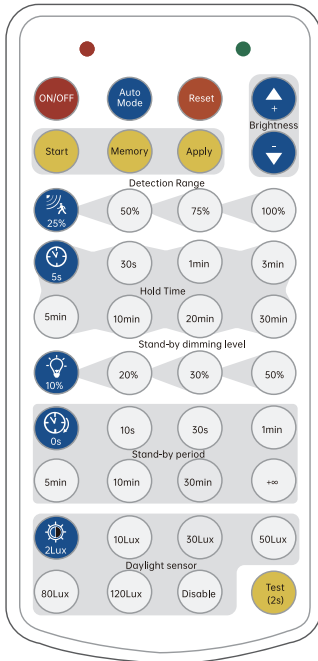





Please read these instructions carefully before commencing any work.

- This unit must be fitted by a competent and qualified electrician.
- To avoid damage, falling, electric shock, or fire, please do not modify the lamp and replace accessories without confirming with the supplier.
- Maintenance/installation and replacement of the lamp, please confirm to cut off the power supply, and the lamp has set up a cooling. Please make sure the lamp has been properly installed before processing power.
- Ensure the lamp is in an accurate and reliable connection.
- Ensure that the product around the vent, and the lamp cannot violate any fire prevention regulations when used.

Remote For Dimming Sensors



Programable IR Remote Controller User Manual

Key	Function	Performance
	ON/OFF	<ol style="list-style-type: none"> 1. Switch ON/OFF the light. 2. Turn on the light as permanent on without sensor mode.
	Auto Mode	Switch to sensor mode and all sensor settings will recovery to the latest setting.
	Reset	Reset the sensor to default mode: 100% brightness, hold time 5min, stand-by period +∞, 100% sensitivity, daylight sensor diasable.
	+/- Brightness	<ol style="list-style-type: none"> 1. To adjust brightness 20%-100% in on/off mode. 2. To adjust highest brightenss 60%-100% in sensor mode.
	Program Mode	Press "Start" to customize scene, users can change detection range, daylight threshold, holdtime, standby dimming level and standby period.
	Save Setting	<ol style="list-style-type: none"> 1. Press "Memory" to save all the settings. 2. The settings remained as the last time if not get resetted values.
	One Key Apply	<ol style="list-style-type: none"> 1. Press "Apply" to deliver the saved setting. 2. Press "Apply" without "memory" will make all the setting one-time operation. 3. Settings should be done within 30S, otherwise it exits memory mode.
	Detection Range	Detection range (Press to define detection area 100%/75%/50%/25%)
	Hold time	Hold time (Press to define holdtime 5s/30s/1min/3min /5min/10min/ 20min/30min)
	Stand-by dimming level	Stand-by dimming level (Press to define stand-by dimming level 10%/20%/30%/50%.)
	Stand-by period	Stand-by period (Press to define stand-by period 0s/10s/30s/1min/ 5min/10min/30min/+∞.) Note: "0s" means no standby period; "+∞" means unlimited standby period.
	Daylight threshold	Daylight threshold (Press to define daylight level 2Lux/10Lux/30Lux/ 50Lux/80Lux/120Lux/Disable.) Note: Disable means light will be turned on once sensor detects motion no matter what ambient lux.
	Test Mode	Sensor turn to test mode: The light will flash 3 times in 5s, after 5s sensor quit the test mode and resume to the latest setting.