

Emergency Tri-proof Light-B

0.6/1.2/1.5m

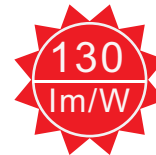

Certificates



Product Description:

- C Serise Lamp strip LED
- Natural silicon gel gasket used in the housing
- PC clips or stainless steel clips for locking and waterproof cable gland on side of the housing to ensure good waterproof function
- Only PC househol der and diffuser(PC) to meet different requests
- PC wire clips to ensure electrical safety
- Prismatic diffuser with unique shape design to get average ray, efficient usage of light and good dazzle-proof effect
- Easy and quick to installation under ceiling or on surface
- Plastic gear tray holder connected to the housing for easy maintenance
- Reflector: MCPCB or PCB for your option

Application

indoor and outdoor lighting, with IP65, it can be used at chick en farm, basement, car p arking, warehouses, corridors, outside of building, etc



Dimension (Unit: mm)

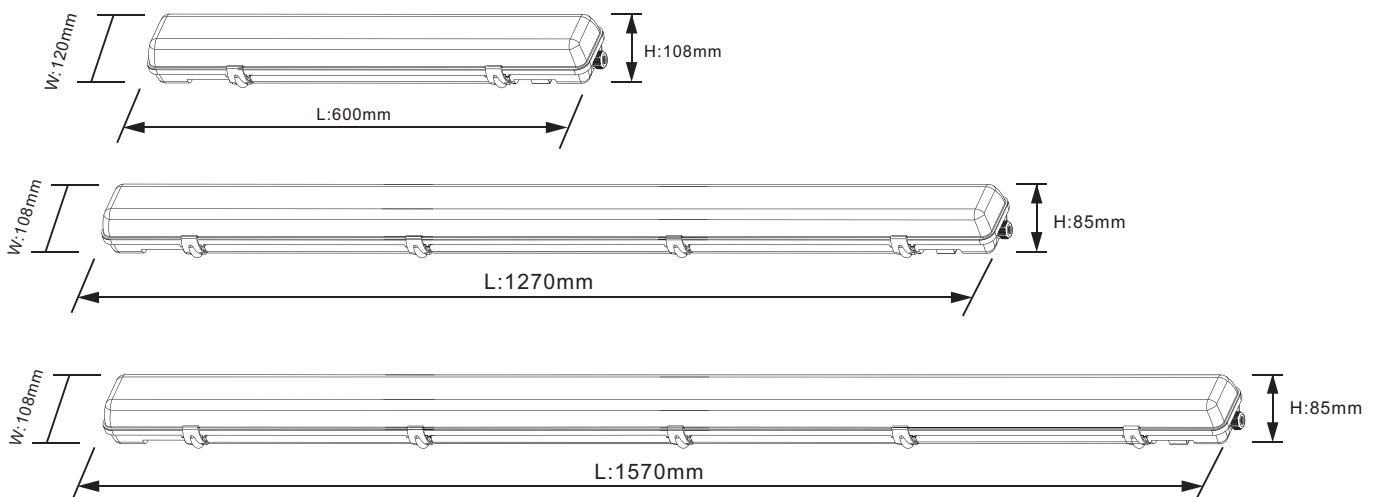

A: Technical Parameter

0.6m

Item	UL-TRI-18W-B-EM
Dimension	600×120×108 mm
Power	18W
Lumen (±10%)	2340lm
Emergency Power	2W
Battery	Li-ion 6.4V 9.6Wh 1500mAh 18650
Voltage	AC220V-240V;50/60Hz
LED Type	SMD2835
Color Temperature (CCT)	2700-6500K
Beam Angel	120°
Color Rendering Index (CRI)	Ra>80
Power Supply Efficiency	>95%
LED Luminous Efficiency	130lm/W
Power Factor (PF)	>0.95
IP Rank	IP 65
Certificate	C-TICK, SAA, CE, CB
Material	PC+AL

1.2m

Item	UL-TRI-24W-B-EM	UL-TRI-36W-B-EM	UL-TRI-40W-B-EM
Dimension	1270×108×85 mm	1270×108×85 mm	1270×108×85 mm
Power	24W	36W	40W
Lumen (±10%)	3120lm	4680lm	5200lm
Emergency Power	4W	4W	4W
Battery	Li-ion 6.4 19.2Wh 3000mAh 18650	Li-ion 6.4 19.2Wh 3000mAh 18650	Li-ion 6.4 19.2Wh 3000mAh 18650
Voltage	AC220V-240V;50/60Hz		
LED Type	SMD2835		
Color Temperature (CCT)	2700K-6500K		
Beam Angel	120°		
Color Rendering Index (CRI)	Ra >80		
Power Supply Efficiency	>95%		
LED Luminous Efficiency	130lm/W		
Power Factor (PF)	>0.95		
IP Rank	IP 65		
Certificate	C-TICK, SAA, CE, CB		
Material	PC+AL		

A: Technical Parameter

1.5m

Item	UL-TRI-50W-B-EM
Dimension	1570×108×85 mm
Power	50W
Lumen (±10%)	6500lm
Emergency Power	4W
Battery	Li-ion 6.4 19.2Wh 3000mAh 18650
Voltage	AC220V-240V;50/60Hz
LED Type	SMD2835
Color Temperature (CCT)	2700K-6500K
Beam Angel	120°
Color Rendering Index (CRI)	Ra >80
Power Supply Efficiency	>95%
LED Luminous Efficiency	130lm/W
Power Factor (PF)	>0.95
IP Rank	IP 65
Certificate	C-TICK, SAA, CE, CB
Material	PC+AL

Packing

A: Packing Information

Item	UL-TRI-18W-B-EM	UL-TRI-24/36/40W-B-EM	UL-TRI-50W-B-EM
Box Size	63.2*24.5*24.5	133*24.4*29	163*24.4*29
G.W.	6.5kg	12.6kg	16.4kg
QTY/Box	9pcs	6pcs	6pcs

Compliance and Standards

1

The IR shall be at least 50MΩ when apply 500Vdc between primary and secondary

2. Dielectric Strength (Hi -pot)

Input To Output 3750Vac 60Hz 1minute ≤3MA

When AC voltage of 3.75KV is applied, and the voltage applied to the insulation under test is gradually raised from zero to the prescribed voltage in 1s, and held at that value for 60s between the inputs. and output and between the input and housing, the current sensitivity shall be less than 5mA. After this test, the adapter shall exhibit no electrical and mechanical abnormalities.

3. Leakage Current

The leakage current shall be less than 0.25mA for class II when power supply is operated maximum input voltage and maximum load.

4. Safety Standard

3A-1501NP IEC:60598-1:2008 IEC61347-1/A1:2010 IEC61347-2-13:2006 IEC62031:2008

IEC62471:2006 IEC62471-2:2009: Passed

EN60598-1/A11:2009 EN61347-2-13:2006 EN61347-1/A1:2011 EN62031:2008 EN62471:2008

EN61195:1999 EN62493:2010: Passed

5. EMI/EMS Standard

EN55015:Passed

EN61000-3-2:Passed

EN61000-4-2:Passed